

W	B	H
5'	2'	0.08' (1")
6'	2'	0.08' (1")
8'	4'	0.08' (1")

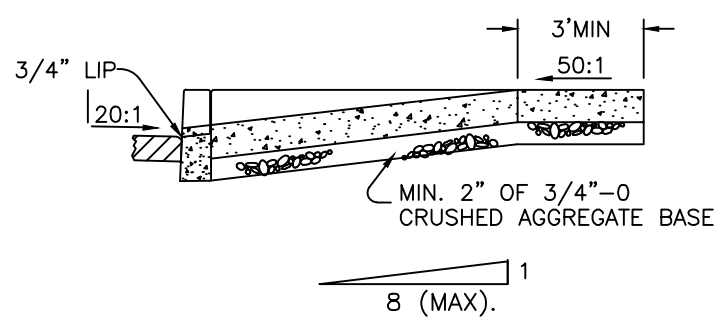

TYPICAL SECTION THROUGH DRIVEWAY/ALLEY RAMP

NOTES:

1. RESIDENTIAL DRIVEWAYS AND SIDEWALK SECTIONS THROUGH DRIVEWAYS SHALL HAVE A MINIMUM NOMINAL THICKNESS OF 4". CONCRETE STRENGTH SHALL BE 3300 PSI.
2. CONCRETE FOR COMMERCIAL USE AND ALLEY APPROACHES SHALL HAVE A MINIMUM NOMINAL THICKNESS OF 6". CONCRETE STRENGTH SHALL BE 3300 PSI.
3. CURB TRANSITIONS FOR COMMERCIAL USE AND ALLEY APPROACHES SHALL BE 5 FEET.
4. CONSTRUCT CONTRACTION JOINT IN CENTER OF DRIVEWAY WHEN DRIVEWAY WIDTH EXCEEDS 15'.
5. NO LIP AT GUTTER LINE IF USED AS SIDEWALK ACCESS RAMP.
6. SEE SIDEWALK DETAILS FOR RESTRICTIONS AND SPECIFICATIONS NOT SHOWN.
7. THE 50:1 CROSS-SLOPE OF SIDEWALK IS MEASURED FROM HORIZONTAL. THE 12:1 SLOPE OF SIDEWALK TRANSITION TO DRIVEWAY/ALLEY IS RELATIVE TO THE RUNNING SLOPE OF THE SIDEWALK. THE SLOPE OF THE APRON IS MEASURED RELATIVE TO HORIZONTAL.

CITY OF SANDY	
DRIVEWAY AND ALLEY APPROACHES WITH DEPRESSED CURBLINE SIDEWALK	
DATE: SEPT 1997	DRAWING NO. 208